

4-GPEKH-145

OPERATION MANUAL

HEAT SHRINK MACHINE

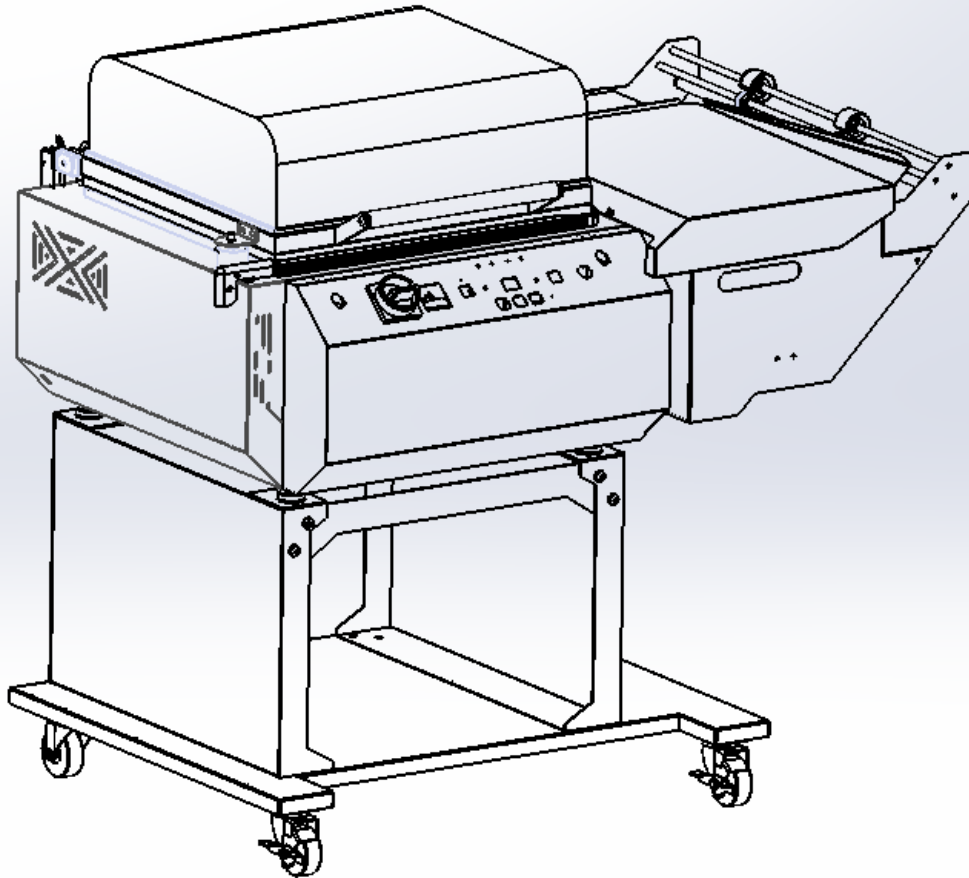

OPERATION MANUAL

2021-11-17



02 9452-3566
sales@getpacked.com.au

1 GENERAL SAFETY INSTRUCTIONS

| | | |
|-----|---|----|
| 1.1 | Basic Operation | 5 |
| 1.2 | Basic Safety Precautions | 5 |
| 1.3 | Safety Instructions Governing Specific Operational Phases | 6 |
| 1.4 | Warning of Electrical Dangers | 7 |
| 1.5 | Grounding Instructions Shall Include the Following | 8 |
| 1.6 | Before Operating | 9 |
| 1.7 | During Operation | 9 |
| 1.8 | After operating | 9 |
| 1.9 | Signs | 10 |

2 MACHINE INFORMATION

| | | |
|-----|--|----|
| 2.1 | Areas of Application | 11 |
| 2.2 | Environmental Information | 11 |
| 2.3 | Machine Description | 12 |
| 2.4 | Safety Devices | 13 |
| 2.5 | Technical Specification | 15 |
| 2.6 | Identification Data of the Machine | 17 |

3 BEFORE OPERATING THE MACHINE

| | | |
|-----|---|----|
| 3.1 | Shipping | 18 |
| 3.2 | Unload Machine from Pallet & Installation | 18 |
| 3.3 | Operation Space | 19 |
| 3.4 | Construction and Units | 19 |
| 3.5 | Operate Panel | 20 |
| 3.6 | Film Threadin | 22 |

4 OPERATING THE MACHINE

4.1 Machine operating23
4.2 Setting25

5 TROUBLE SHOOTING..... 27

6 MAINTENANCE..... 28

7 ELECTRIC WIRING DIAGRAM & PART..... 31

8 PART LIST..... 34

1. GENERAL SAFETY INSTRUCTIONS

1.1 Basic Operation

- The manual and the safety remarks are to be read before use. The operator manual should be kept with the machine at all times. Intervals for maintenance and inspections are to be adhered to.
- This machine was built with state of the art technology and rigid adherence to safety standards.
- Unless used properly, it can cause injury to operators or persons in close proximity to the machine. In addition, improper use can cause damage to the machine or property around the machine.

1.2 Basic Safety Precautions

- The user is to be instructed in all other generally applicable legal and other mandatory regulations relevant to accident prevention and environmental protection in addition to the operating instructions.
- For safety reasons, long hair must be tied back or otherwise secured, garments must be close fitting and no jewelry may be worn.
- Use protective equipment where required by circumstances or by law.



- Carefully observe all safety instructions and warnings attached to the machine and make sure that they are always complete and perfectly legible.
- Always make certain that persons being trained and instructed in working on or with the machine are permanently supervised by an experienced person.
- Work on the electrical system and equipment of the machine is only to be carried out by a skilled electrician or by persons under the supervision and guidance of a skilled electrician and in accordance with the rules and regulations of electrical engineering.

1.3 Safety Instructions Governing Specific Operational Phases

- Avoid any operation mode that might be unsafe.
- All necessary precautions to ensure that the machine is only used being in a safe and reliable state are to be taken. The machine is only to be operated if all protective and safety devices, including removable safety devices, emergency shut-off equipment, noise-protection elements and exhaust systems are in right place and fully functional.
- The machine is to be checked for damage and defects at least once per work shift. Any changes including the working behavior of the machine are to be reported to competent persons immediately. If necessary, the machine is to be stopped and locked immediately.
- In case of any malfunction the machine must be stopped and locked until the defect has been eliminated.
- Generally make sure that nobody is at risk before starting up the machine.
- All personnel that will be operating this machine should be thoroughly trained in all phases of operation and safety.
- Always tighten unscrewed connections after maintenance and repair.
- After completing maintenance and repair all safety devices removed for setting up or repairing the machine must be reinstalled and checked for functionality prior to putting the machine back into service.
- To minimize the environmental impact all consumables and replaced parts must be disposed of safely.
- Before starting the machine check that the accessories have been stowed away safely.
- Do not attempt any operation that may be a risk to the stability of the machine.

1.4 Warning of Electrical Dangers



- Immediately remove power to the machine in case of trouble in the electrical system.
- Replace a fuse with one with the same style and ratings; pay particular attention to matching the specified current.
- Any electrical work performed on the equipment must be conducted by a skilled electrician or under the supervision of a skilled electrician. All work must be observed good electrical engineering practice and follow safety rules and local wiring standards.
- Inspect the electrical equipment of the machine at regular intervals. Tighten any loose connections. Check wiring for scorch marks; replace scorched wiring and determine and correct the reason for the overheating.
- When working on live equipment, ensure that a second person is available to cut power in case of an emergency. When appropriate, secure the working area with safety tape and a warning sign. Use insulated tools for electrical work.
- Before working on high-voltage assemblies, turn off the power supply. Carefully discharge the supply cable and short-circuit any energy-storage components such as capacitors.
- If the equipment was moved, carefully refit and refasten all parts removed for transport before reapplying power.
- Before moving the machine, remember to disconnect the power cable.

1.5 Grounding Instructions Shall Include the Following

- This product must be grounded. In the event of an electrical short circuit, grounding reduces the risk of electric shock. This product is equipped with a cord that has a grounding wire and an appropriate grounding plug. The plug must be plugged into an outlet that is properly installed and grounded in accordance with all local codes and ordinances.
- If repair or replacement of the cord or plug is necessary, connect the ground wire to the ground terminal of the plug. The wire with green insulation (with or without yellow stripes) is the grounding wire.
- Check with a qualified electrician or service person if the grounding instructions are not clear or if in doubt about the proper grounding of the machine. Do not modify the plug provided; if it will not fit the power outlet, have the proper outlet installed by a qualified electrician.
- This product is designed for use on a nominal AC circuit and has a grounding plug.

DANGER!

Improper installation of the grounding can result in electrocution.

1.6 Before Operating

- Verify that the power line voltage is correct.
- The machine must be properly grounded to avoid a shock hazard. All wiring must be in accordance with local wiring standards.
- The heat shrink machine can only be operated with PVC or POF film.







1.7 During Operation

- The size of the package should be under dimension in specification list.
- While running, check the unit for any unusual sounds or smoke emissions.
- Keep away from the inside of the chamber while the machine is operating; do not put your hands or body inside the chamber when the machine is running.

1.8 After operating

- Remove dust and dirt from the unit
- Turn off the power when the machine is not in use.

1.9 Signs

| | |
|---|---|
|  | <p>Caution! Electric Shock Hazard.</p> |
|  | <p>Caution! Hot Surface.</p> |
|  | <p>Caution! Moving Parts Can Crush Hand.</p> |
|  | <p>Caution! Pinch Point Entanglement</p> |
|  | <p>Caution! Blade. Cutting of Fingers or Hand</p> |
|  | <p>Wear Eye Protection</p> |
|  | <p>Refer to Operator Manual</p> |

2. MACHINE INFORMATION

2.1 Areas of Application

Packaging Limitation

It's not possible to pack:

- Products larger or heavier than that allowed.
- Wet Products
- Flammable products
- Explosive products
- Agri-foodstuffs
- Pharmaceuticals
- Hazardous products

2.2 Environmental Information

The strapping machine shall be installed in the following conditions:

- Supply voltage: +/-10% nominal supply voltage
- Source frequency: +/-10% nominal frequency
- Ambient temperature: 5°C - 40°C (41°F-104°F).
- Relative humidity: not exceed 35~85%RH
- Please provide a suitable illumination around the machine for safety operation.

Conditions For Use

Make sure there is room for easy application and maintenance

The machine must be installed in a closed, well-ventilated area where there are no explosions or fire hazards Position the machine in a place free of humidity, flammable materials, gas or explosives. Make sure that it is level.

Please do not spray water or wet wipe machine body.

Noise - characteristic values

The noise emission values determined according to EN ISO 3746 for the sound power level or EN ISO 11202 for the sound pressure level at the workplace on the basis of the working conditions are as below:

A measurement uncertainty allowance of $K = 4 \text{ dB(A)}$ applies to the stated emission values.

Sound power level $L_{WA} = 88.7 \text{ dB(A)}$

Emission sound pressure level at the workplace $L_{PA} = 75.3 \text{ dB(A)}$

To minimize the emission sound pressure level, machine is equipped with a timer standby mode that can be adjusted by technician.

Demolition and Waste Disposal

The machine does not contain dangerous components or substances which require special disposal procedure. For that which concerns material elimination, comply with the Standards in the country where the machine has been disassembled.

2.3 Machine Description

This machine is manually operated to shrink wrap PVC or polyolefin shrink films tightly around the products by circulating hot air inside, or make loose bag without shrink wrapping. The film is cut at the same time while shrink process by pressing down the shrink hood. It is suitable for single product wrapping or combination of multiple products into one package for protection and good appearance

2.4 Safety Devices

DANGER!

Operate the machine only when all safety devices are at their place and are functioning correctly.

The machine has been constructed in accordance with the applicable legal regulations.

The machine is reliable in operation. Nevertheless the machine may constitute a danger if it is operated in improper or undue condition.

Danger points that cannot be avoided due to equipment design are equipped with safety devices. If necessary, these points are marked on the machine with warning signs, and in the manual under working safety instructions.

The machine is equipped with safety devices as:

- Warning labels
- Live parts are covered

Only PVC and POF films can be used in this machine. The use of other synthetic films can produce substances hazardous to health.



Caution!

The heating unit operates at a very high temperature in order to offer surrounding temperature in chamber to shrink film apply to product.

To prevent burns, avoid touch the sealing blade. (1)

To adjust pin-perf system, avoid to directly touch the pin area though there is cover already cover around the danger area. (2)

To move the machine, the two lockable casters (3) must be unlocked. Relock the two casters when the machine is in its new position.

In certain condition, you might need the emergency stop which we offer as option.

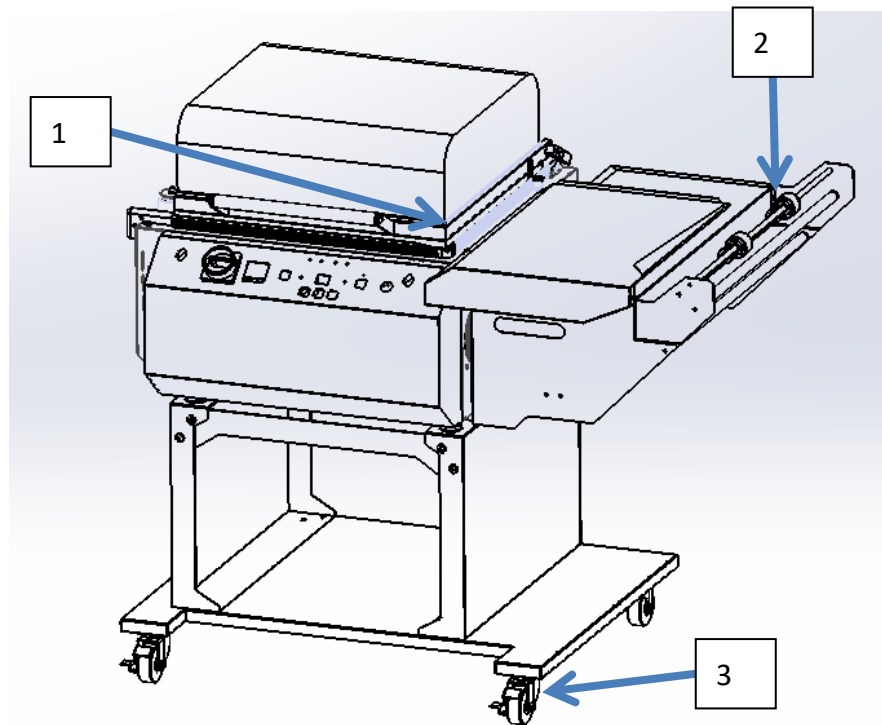

The machine is turned on when it is connected to AC power. The main power switch which located on the front operating panel is placed in the ON position, and also presses Start Switch (A) to start machine. After approximately 5 minute, the heating element will reach its operating temperature then the indicator light will turn to GREEN (A) and the machine will be ready for use.

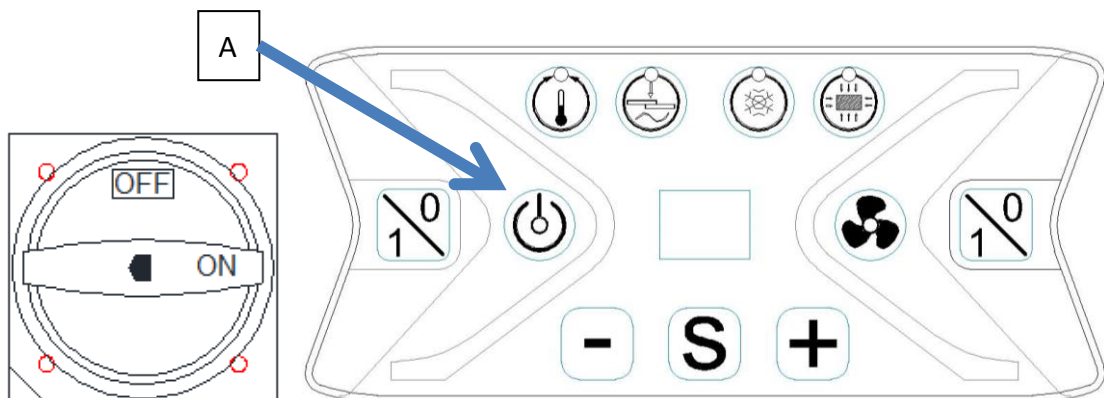

Caution!

2.5 Technical Specification

2.5.1 Electrical Specification

| | |
|----------------------|---------------------|
| System Configuration | L1+N+PE (GROUND) |
| Nominal Power | 3.77kW |
| Rated Current | 16.4 A |
| Rated Voltage | 200V/220V/230V/240V |
| Rated Frequency | 50 /60Hz |
| Type of Current | AC- single phase |

2.5.2 Technical information

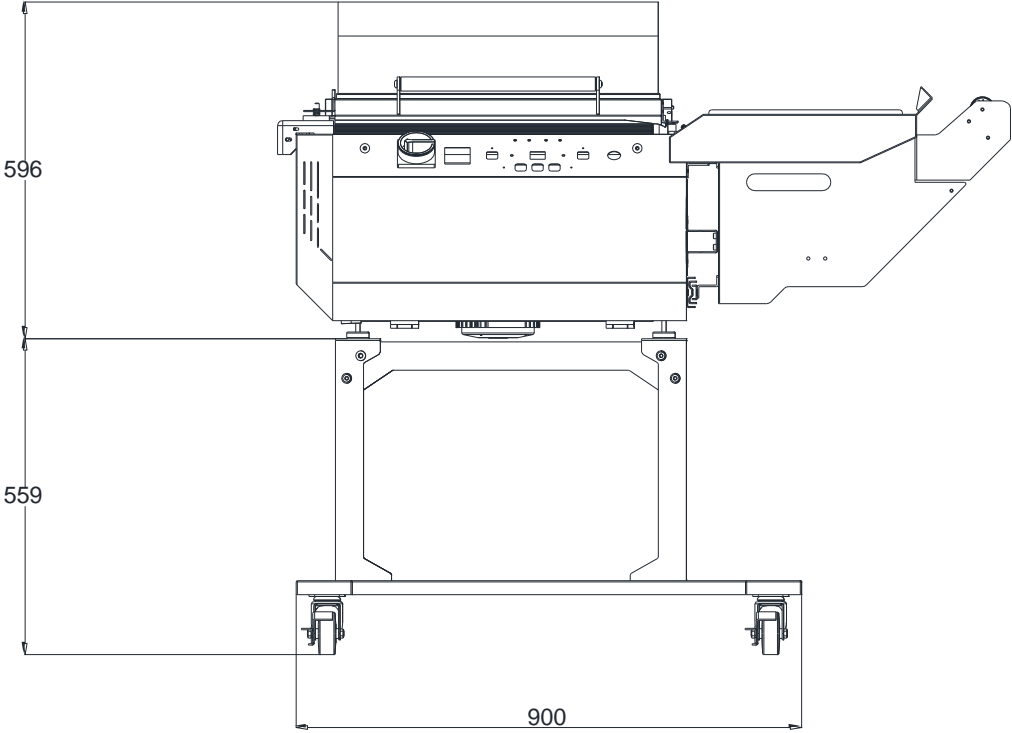
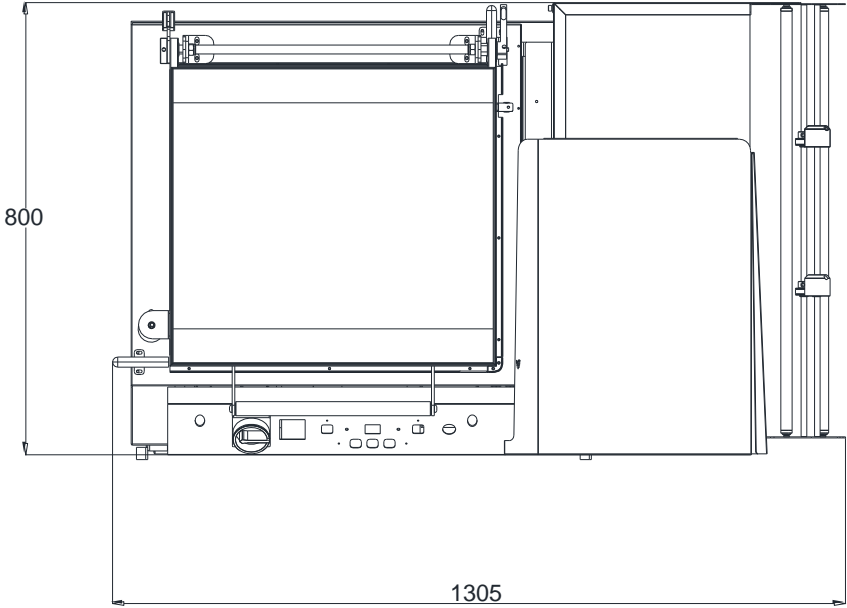

| | |
|----------------------|--|
| FILM MATERIAL | PCV, POF |
| FILM THICKNESS | < 50 micrometer |
| FILM WIDTH | 600mm |
| FILM OUTER DIA. | 300mm |
| FILM INNER CORE DIA. | 77mm |
| FILM WIDTH SELECT | Product Width + Product Height + 50mm |
| SEALING DIMENSION | 550mm * 415mm |
| PRODUCT HEIGHT | < 300mm |
| PRODUCT WEIGHT | < 15Kg |
| NOISE EMISSION | 60 dB |
| AMBIENT TEMP. | 5°C - 40°C |
| WORKING HEIGHT | 950mm |
| MACHINE SIZE | (L)1305mm x (W)800mm x (H)1155mm with stand (L)1305mm x (W)800mm x (H)596mm without stand |
| MACHINE WEIGHT | 135Kg |

2.6 Identification Data of the Machine

Each model is provided with a plate where it is easy to recover data which must be communicated to the manufacturer in case of problem or when requesting spare parts etc. (ref. 1-2-3-4) This plate also carries electrical technical data for installation of the machine. (ref. a-b-c-d-e-f-g).

EXTEND
20F, No. 309, Sec. 2, Taiwan Blvd.,
Taichung, Taiwan, R.O.C.

CE

HEAT SHRINKING MACHINE

MODEL: EKH-145 (1)

SERIAL: H18040151 (2)

YEAR: 2018 (3)

DOC NO.: EKH-145-01-B-230 (4)

| | | | |
|----------------------------|--|------------------------|-----------------------------|
| Volt 230V (a) | Hertz 50Hz (c) | Phase 1~ (e) | Watt 3.77 kW (f) |
| Ampere 16.4A (b) | Short Circuit Rating 6kA (d) | | Weight 135 kg (g) |

1. Model
2. Serial Number
3. Year of Manufacture
4. Doc. Number
- a. Rated voltage (V)
- b. Rated Current (A)
- c. Frequency (Hz)
- d. Short Circuit Rating (A)
- e. Phase (PH)
- f. Rated power (Watts)
- g. Weight (kg)

3. BEFORE OPERATING THE MACHINE

3.1 Shipping

The machine is delivered as a transport unit. The machine is loaded onto a wooden pallet with Polyester strap secured. Outside with carbon box also with Polyester strap secured.

3.2 Unload Machine from Pallet & Installation

Cut Polyester strap and then move the carbon box upward.

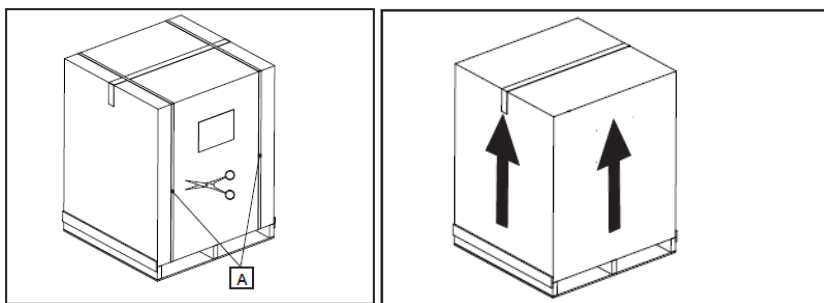

Assemble the seat and make sure to lock the caster, then remove strap around the machine and use forklift to move the machine upon the seat in position.

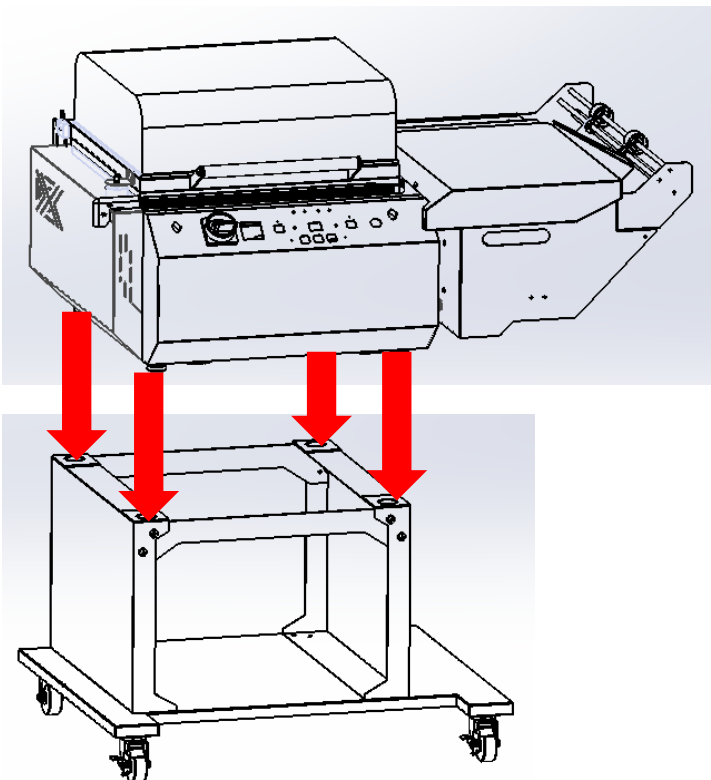

3.3 Operation Space

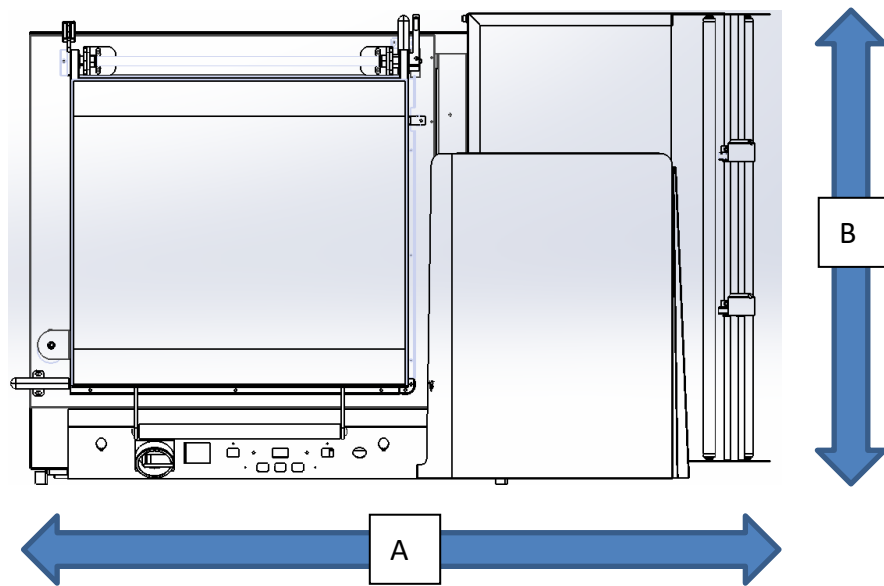

Keep the area (A) and (B) free for the operator.

The area (A) is necessary for operating heat shrink machine.

The area (B) is necessary for changing the film.

3.4 Construction and Units

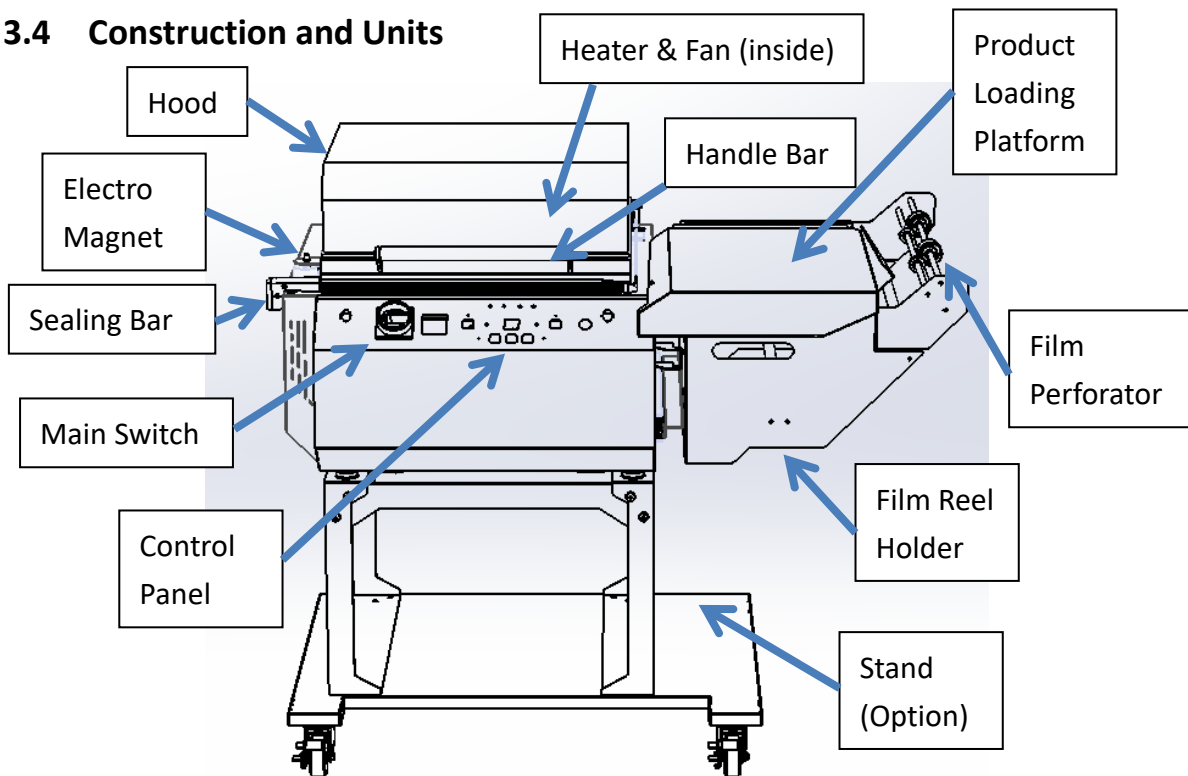

3.5 Operate Panel

a. Main Power Switch:

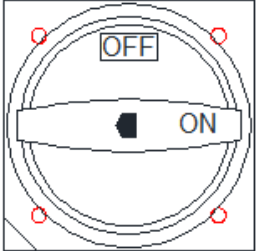

b. Control Panel:

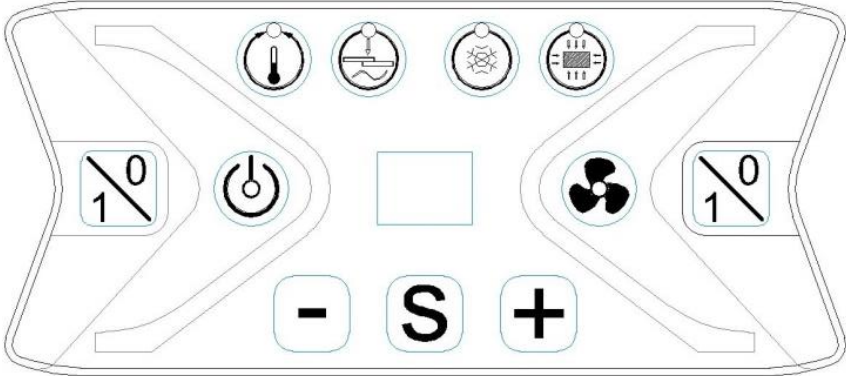

c. Start Switch:

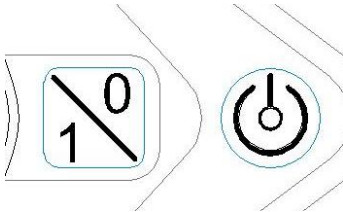

d. Shrink Switch:



e. Setting:



Press "S" then you are able to do settings of followings:

- Shrinking Temperature:



- Sealing Timer:

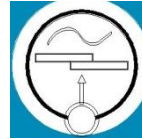

- Cooling Timer



- Shrinking Timer

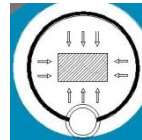

3.6 Film Threading

a. Please remove the film seat unit from the machine

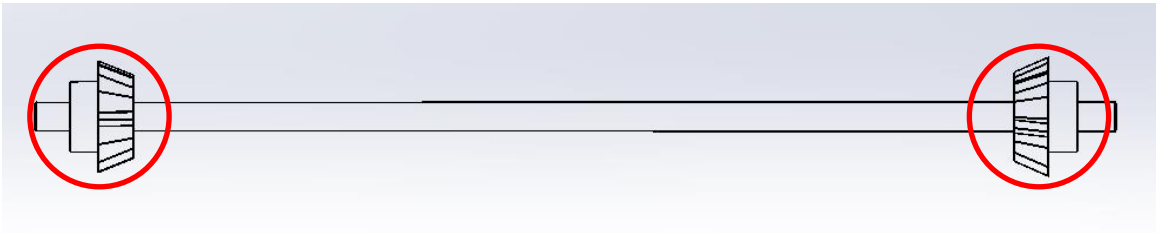

b. Remove the film holder on one side, install the film and then fix the film holder on both sides to proper position

c. Follow the below drawing for film threading

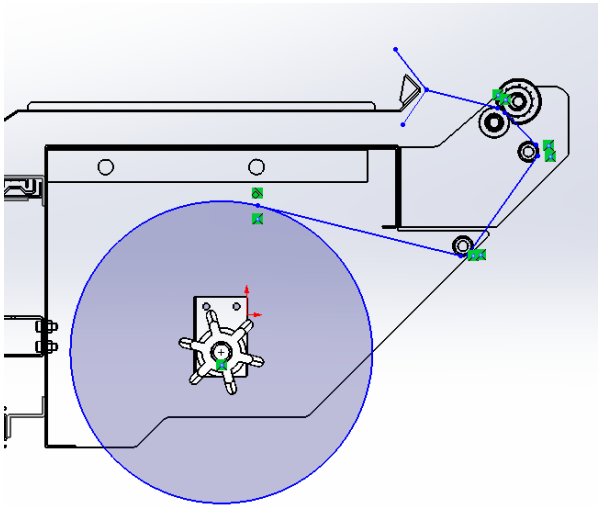

4. OPERATING THE MACHINE

4.1 Machine operating

- a. Turn the machine power switch ON

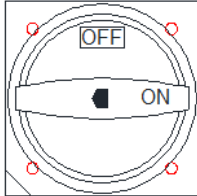

- b. Turn the Start Switch ON, and wait for the temperate ready (the indicator light turns to GREEN)

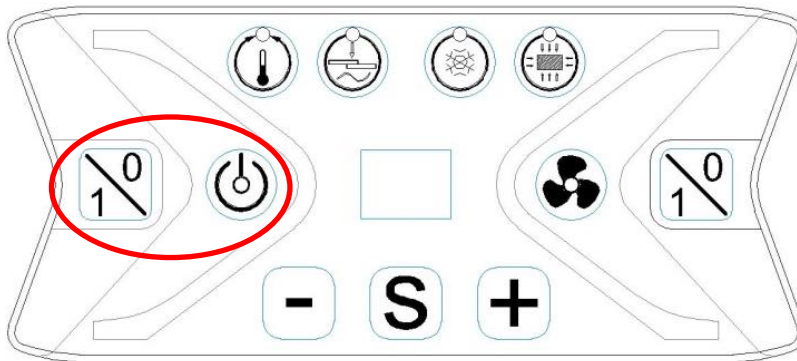

- c. Installed shrink film (follow instruction 3.6)
- d. Adjust film loading seat (A) and product platform (B) to fit with your product size

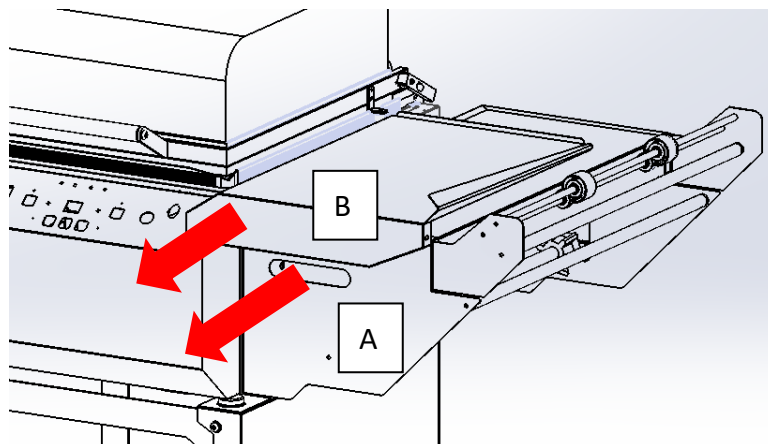

- e. Close down the shrink hood, until the sensor is activated, then the magnetic will hold the hood for sealing

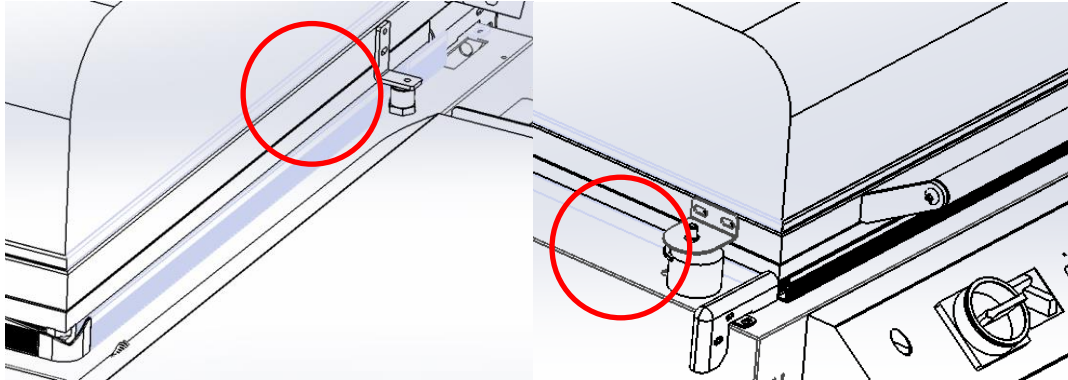

- f. Please pre-head the sealing bar for 3-5 times without film
- g. Pull the film with product into the tray area, close down the shrink hook_ **with some extra force** for easier cutting, to make sure the cutting & sealing is good

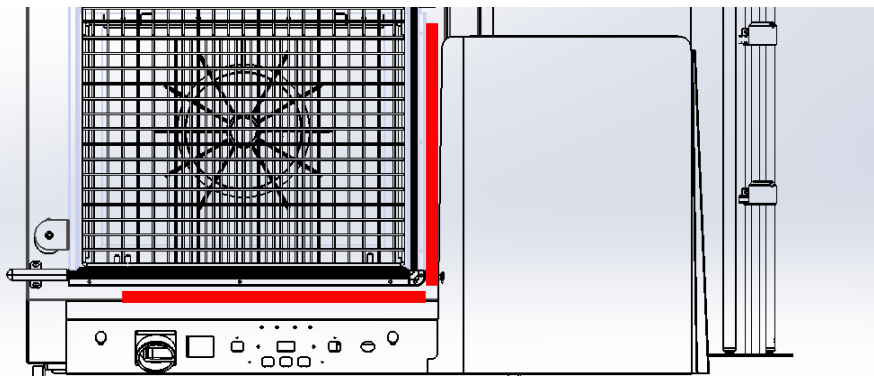

- h. Turn the Shrink Switch ON, then the cycle will include the shrinking function.



4.2 Setting

For the control panel setting, please press “S” button to select the parameter you want to adjust (the selected function will have indicator light ON), then press “+” & “-” button to adjust the following settings.

➤  Shrinking Temperature

This controls shrinking temperature inside the chamber, you are able to adjust from level 1 to 10 (with min 100 to max 210)

- ✘ Factory setting is level 4 to 6
- ✘ This setting could be adjusted due to different product size, film thickness, surrounding temperature.

➤  Sealing Timer

This controls sealing timer for the sealing bar, you are able to adjust from 0.2 sec to 2.0 sec

- ✘ Factory setting is 1.2 sec
- ✘ This setting could be adjusted due to different film thickness, surrounding temperature.

➤  Cooling Timer

This controls cooling timer after sealing, you are able to adjust from 0 sec to 10 sec (if you adjust 0 for cooling timer, the fan will start rotate once the cycle starts; if you adjust 0.1 or above for the cooling timer, the fan will start after the cooling timer)

✘ Factory setting is 0 sec

✘ This setting could be adjusted due to different film thickness or film performance

➤  Shrinking Timer

This controls shrinking timer, you are able to adjust from 1 sec to 20 sec

✘ Factory setting is 4 sec to 6 sec

✘ This setting could be adjusted due to different product size, film thickness, surrounding temperature.

5. TROUBLE SHOOTING

Error list & possible solution

- E1: thermal couple fail:
 - Please check if the cable of thermal couple is loose or broken
 - PCB fail
- E2: heating over 20 mins but still not reach temperature 80 Celsius degree
 - Heating element fail
 - Short circuit for thermal couple
 - PCB fail
 - F3 fuse is blown
- E3: heating over 35 mins but still not reach setting temperature
 - Heating element fail
- E4: cycle finished but the hook still not open over 10 seconds
 - PCB fail
 - Residual Magnetic
- E5: heating element reach over 240 Celsius degree over 5 mins
 - PCB fail
- E6: Over heat, the temperature switch trips OFF
 - Temperature switch is fail
 - Cable #25 & #26 is not fixed well

6. MAINTENANCE

Note: Before doing any maintenance or service, please do switch off the main power on the machine, then wait for the machine to cool down.

Warning:

- a. Wear safety glasses with side shields which conform to ANS Standard Z87.1
- b. Failure to wear safety glasses could result in severe personal injury or blindness.
- c. Wear Ear Protection.
- d. Only trained personnel should service machine.
- e. Unless specified, shut off and disconnect all electrical power.
- f. Follow all service instructions.
- g. Caution for moving parts can crush.
- h. Caution for pinch point entanglement.
- i. Caution for cutting of finger or hand from straight blade.
- j. Use the correct tools.

Cleaning & Lubricate

The machine operates with plastic films which may leave deposits on the sealing blade and affecting sealing quality. Regular machine cleaning is recommended:

The sealing blades:

Keep the sealing blades clean by using a rag or NON-METALLIC scraper (or thumb –nail!) and keep the Teflon tape on the both top jaw clear in same way. Apply a SILICONE LUBRICANT spray to top and Bottom jaws, several times a day, for easier and cleaner machine operation.

Transparent hood:

The transparent machine hood may be kept clean with glass polish or similar-
DO NOT USE SOLVENT CLEANERS

CAUTION IN OPERATION

To in order to make your packaging products Sealed and shrunk completely, you can operate the machine as following:

1. In order to shrink the product, you must make the chamber to be hot by opening and closing the hood repeat when you start or you are asked to operate again in the case of your operation is interrupted.
2. The experience is important to seal and shrink. You will know the appropriate sealing time\shrinking temperature and operating frequency by operating the machine continually.
3. You will be known that only have a good product sealer, your product will be shrunk completely. Therefore, when you operate the machine for sealing or sealing and shrinking, you can close the hood with your high hand, almost at the same time, pull the film by the waste film to move from left to right after sealing time is finished.

ROUTINE MAINTENANCE It is advisable to have two qualified personnel for Maintenance.



BEFORE ATTEMPTING ANY MAINTENANCE:

TURN MAIN SWITCH OFF AND DISCONNECT POWER SUPPLY!



CAUTION HOT!! CAUTION HOT!! SEALING BLADE REPLACEMENT

Undo the screws on the expansion blocks and the central knuckle. Remove the broken seal blade and fit new one after cleaning the sealing base of any deposits/dirt. A piece of Teflon tape around the corner of the wire helps seal quality and insulation of heat. Introduce the end of the front seal blade 15mm inside the plunger to the RIGHT I order to compress the spring. Then tighten the screws. Repeat the process with the tighten the screws on the center buckle.

SILICONE RUBBER REPLACEMENT

The silicone rubber strip inside the top jaw must remain flat and undamaged. If it is necessary to replace the rubber, pull the damaged strip out and clean away any silicone adhesive. Replace the rubber strip using fresh silicone adhesive sparingly. Leave to cure overnight.

REGULAR REPLACEMENT of the TEFLON BARRIER TAPE will increase the life of the Silicone rubber.

TEFLON BARRIER TAPE REPLACEMENT

Remove old Teflon barrier tape before it burns or marks bodily. The tape is supplied on a roll, with self-adhesive backing. Simply cut to length. Remove backing protection and stick in place.

7. ELECTRIC WIRING DIAGRAM & PART

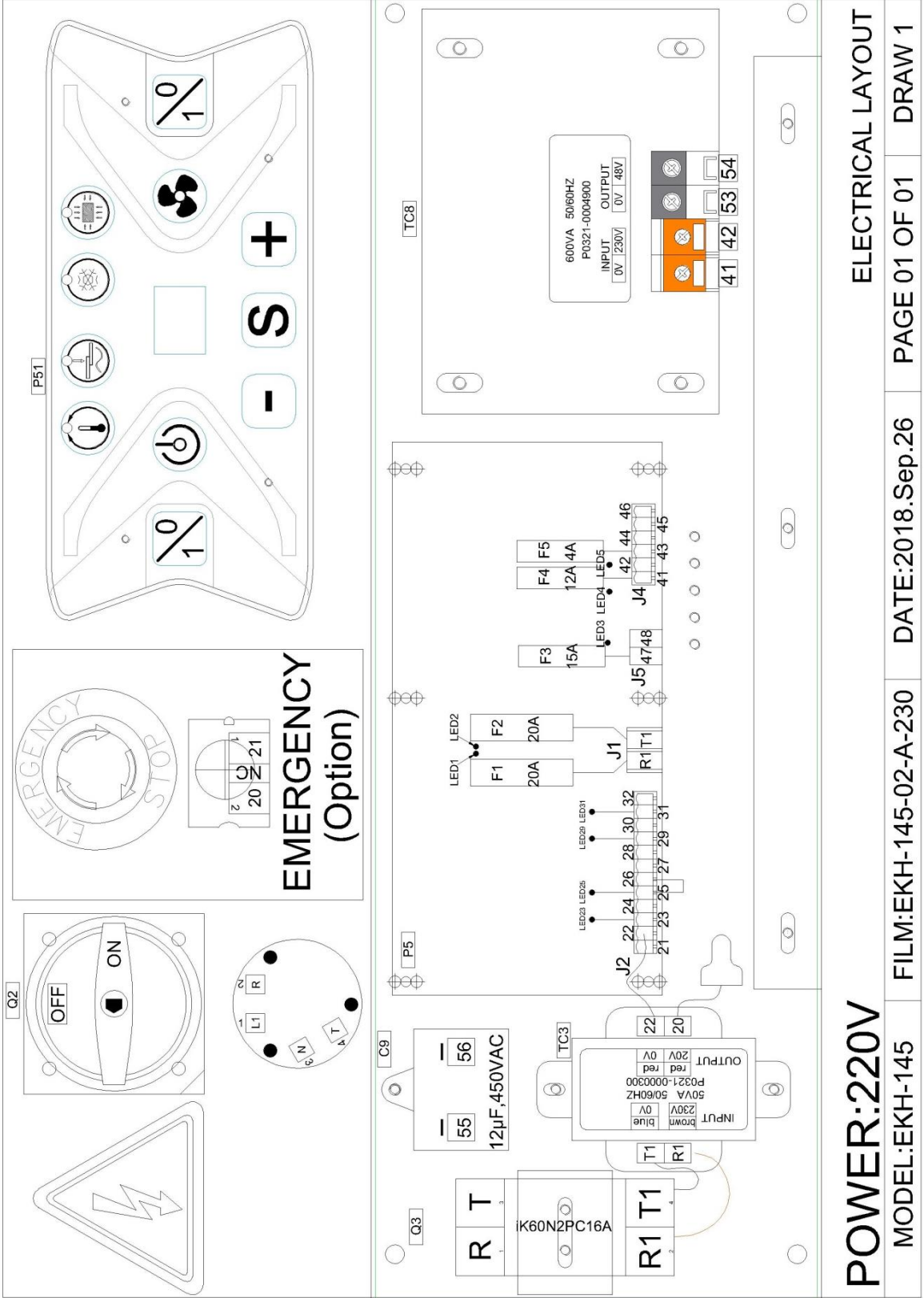

ELECTRIC PARTS LIST FOR EKH-145

| KEY NO | PART NO. | DESCRIPTION | Q'TY |
|-------------------|-----------------|--|------|
| 1 | P1002-000830A | STICKER | 1 |
| Q2 | P0311-010002800 | SEPARATED POWER → ON/OFF | 1 |
| Q3 | P0305-010001200 | CIRCUIT BREAKER IK60N2PC16A | 1 |
| TC3 | P0321-0000300 | CONTROL TRANSFORMER 230V/20V,50VA | 1 |
| 2S5 | P0311-060002400 | SWITCH (Z-15GQ-B AM1307K) | 1 |
| | P0316-030000200 | SWITHC COVER (TAP-Y) | 1 |
| 2K6 | P0301-0001500 | ELETRICAL MAGNET DC24V | 1 |
| ST5 | P0314-050000200 | THERMOCOUPLE (FOTEK TS1, 1.5M) | 1 |
| H8A H8B H8C | P0314-070000100 | HEATING TUBE 230V,900W (FOR 220~240V) | 3 |
| TC8 | P0321-0004900 | HEATING TRANSFORMER 230V/48V 600VA | 1 |
| C9 | 101W12-5060450 | MOTOR CAPACITOR CBB61,12uF/450V,50/60Hz | 1 |
| M9 | P0501-0010600 | MOTOR 220-240V 0.37KW | 1 |
| M10 | P0303-010000200 | AC230V,12CM FAN | 1 |
| P5 | P0309-010010700 | MAIN CONTROL CARD | 1 |
| P51 | P0309-020002500 | TOUCH PANEL | 1 |

Wiring Diagram

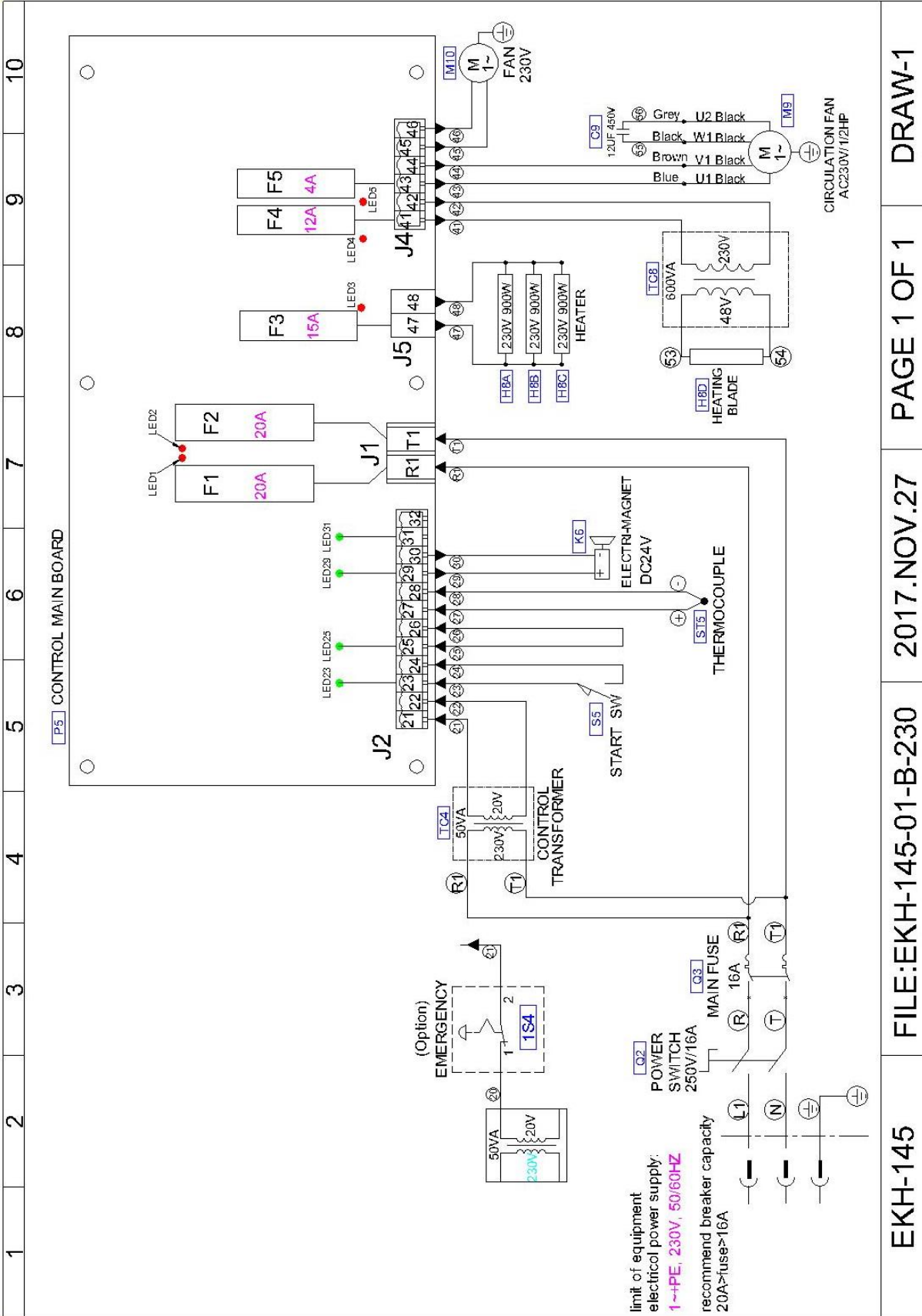

1 2 3 4 5 6 7 8 9 10

8. PART LIST

PIN PERFORATOR UNIT

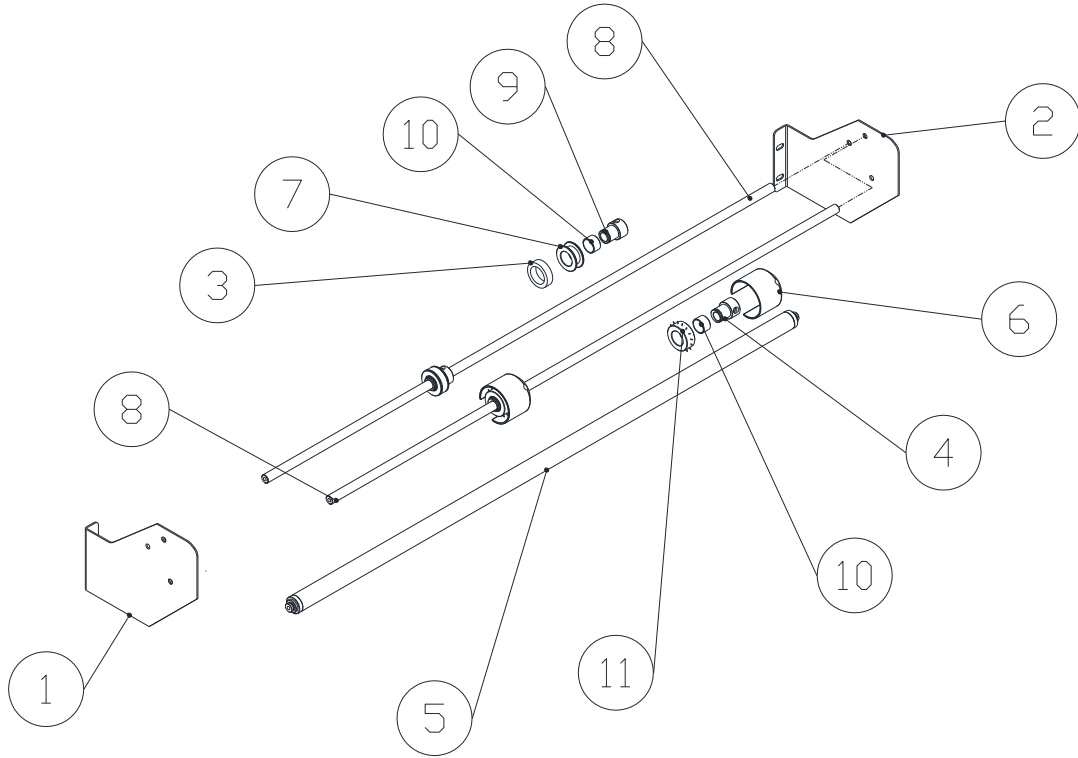

| PIN PERFORATOR UNIT | | | |
|---------------------|---------------|-------------------------|------|
| # | PART NUMBER | ITEM | Q'TY |
| 1 | | SUPPORT BRACKET - LEFT | 1 |
| 2 | | SUPPORT BRACKET - RIGHT | 1 |
| 3 | P06-005940A | RUBBER ROLLER | 2 |
| 4 | P02-031700A | PIN SHAFT | 2 |
| 5 | P08-000950A | ROLLER | 1 |
| 6 | P06-005960A | PIN COVER | 2 |
| 7 | P06-0059300 | PIN COVER | 2 |
| 8 | P02-032000B | SHAFT | 2 |
| 9 | P02-0317100 | RUBBER SHAFT | 2 |
| 10 | P1104-0315101 | BUSHING | 4 |
| 11 | P06-0059200 | PIN | 2 |

MACHINE BODY UNIT

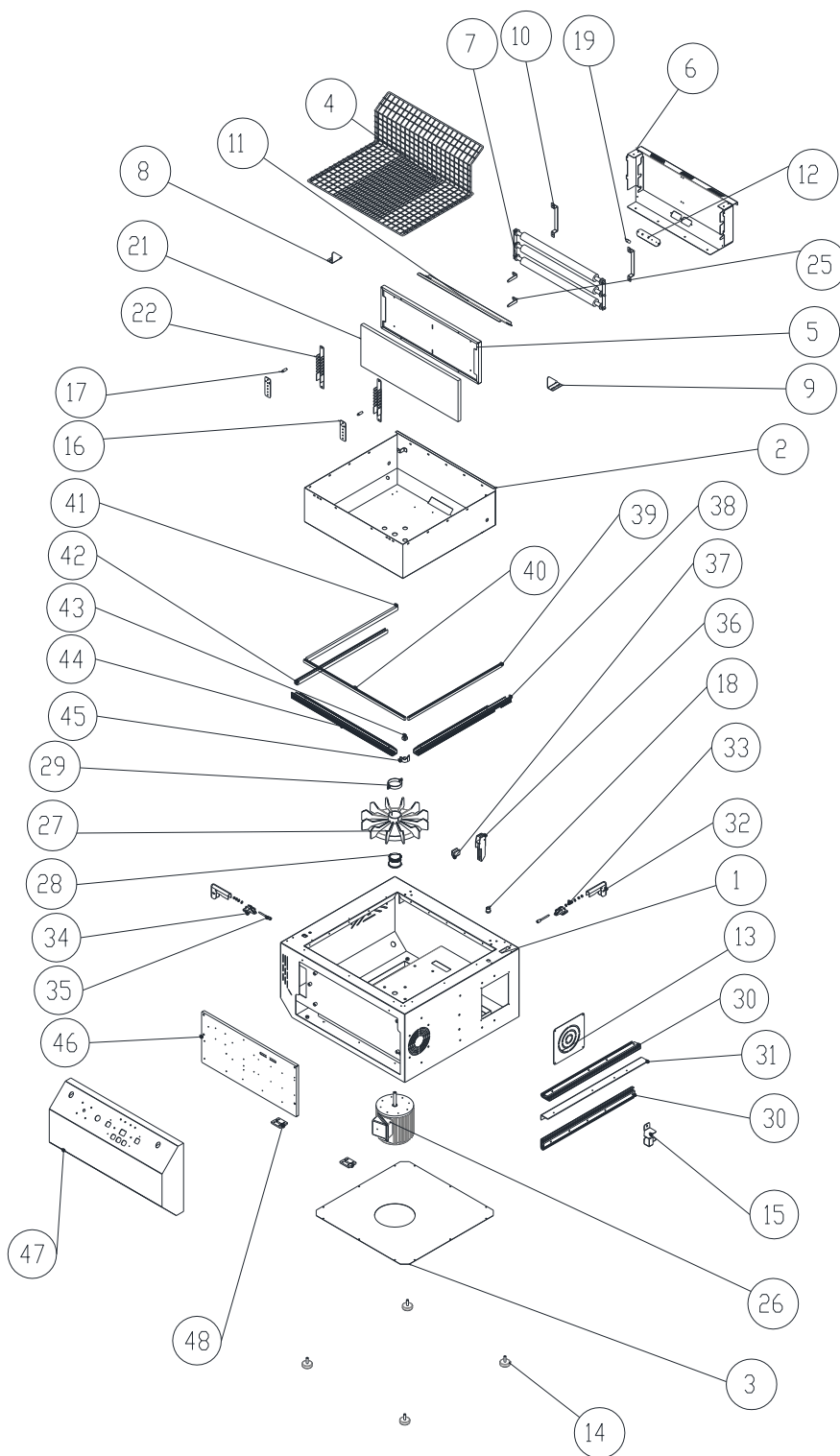

| MACHINE BODY UNIT | | | |
|-------------------|---------------|---------------------------------|------|
| # | PART NUMBER | ITEM | Q'TY |
| 1 | | MACHINE BODY | 1 |
| 2 | | TUNNEL | 1 |
| 3 | | MOTOR COVER | 1 |
| 4 | P02-0319600 | TRAY MESH | 1 |
| 5 | P01-050850C | HEATER COVER | 1 |
| 6 | P01-050860E | HEATER SEAT | 1 |
| 7 | | HEATING UNIT | 1 |
| 8 | P01-050880A | FAN BRACKET - LEFT | 1 |
| 9 | P01-050890A | FAN BRACKET - RIGHT | 1 |
| 10 | P01-050900A | HEATING HOLDER | 2 |
| 11 | P01-0509100 | HEAT OPEN FAN | 1 |
| 12 | | TEMPERATURE SWITCH BRACKET | 1 |
| 13 | | SERVICE COVER | 1 |
| 14 | P1111-0001400 | STAND SUPPORT | 4 |
| 15 | | STOPPER | |
| 16 | P01-0509300 | HOOK | 2 |
| 17 | P02-0233800 | HOOK SCREW | 2 |
| 18 | P02-0317700 | SWITCH COVER | 1 |
| 19 | P02-0234100 | COPPER HEAD | 1 |
| 21 | | COVER | 1 |
| 22 | P01-0548900 | HOOK | 2 |
| 24 | | FIXER | 1 |
| 25 | | BRACKET | 2 |
| 26 | P0501-0010600 | MOTOR 220-240V/50/60Hz,2P,1/2HP | 1 |
| 27 | P06-0067400 | FAN | 1 |
| 28 | P02-023370A | FAN SUPPORT SHAFT | 1 |
| 29 | P01-0273100 | CLAMP | 2 |
| 30 | P1124-0001600 | GUIDE | 2 |
| 31 | P01-050940C | GUIDE SUPPORT | 1 |

| MACHINE BODY UNIT | | | |
|-------------------|-----------------|---------------------------|------|
| # | PART NUMBER | ITEM | Q'TY |
| 32 | P06-006050A | SEALING WIRE COVER | 2 |
| 33 | P1201-0007500 | SPRING | 2 |
| 34 | P06-006020A | SEALING WIRE SEAT COVER | 2 |
| 35 | P02-0173200 | SEALING WIRE SEAT | 2 |
| 36 | P01-050360B | HOOK STOPPER | 1 |
| 37 | P06-0041600 | RUBBER PAD | 1 |
| 38 | P02-0319800 | SEALING WIRE SEAT - RIGHT | 1 |
| 39 | P02-0237400 | SEALING SUPPORT - RIGHT | 1 |
| 40 | P02-0237300 | SEALING SUPPORT - FRONT | 1 |
| 41 | P06-0038900 | RUBBER STICK | 1 |
| 42 | P02-0248100 | SEALING WIRE SEAT - LEFT | 1 |
| 43 | P02-017310A | CORNER SEAT | 1 |
| 44 | P02-0319900 | SEALING WIRE SEAT - FRONT | 1 |
| 45 | P06-0060400 | CORNER SUPPORT | 1 |
| 46 | | ELECTRIC PAD | 1 |
| 47 | | CONTROL PANEL | 1 |
| 48 | P1110-020000500 | HINGE | 2 |

FILM SEAT UNIT

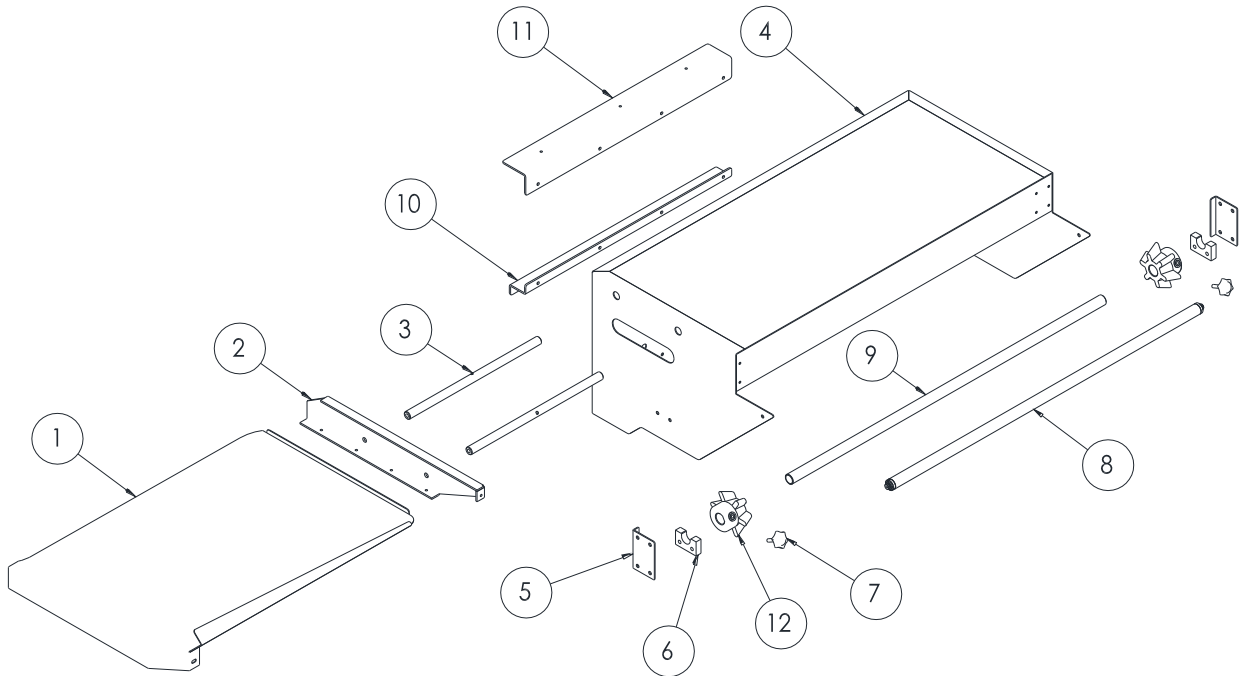

| FILM SEAT UNIT | | | |
|----------------|---------------|-------------------|------|
| # | PART NUMBER | ITEM | Q'TY |
| 1 | P01-0507800 | LOADING PLATFORM | 1 |
| 2 | | SHAFT SEAT | 1 |
| 3 | P02-0319400 | SHAFT | 2 |
| 4 | | FILM SEAT BODY | 1 |
| 5 | P01-0507400 | FILM SEAT STOPPER | 2 |
| 6 | P06-0029600 | FILM SEAT BLOCK | 2 |
| 7 | P1113-0002400 | SCREW M6*25 | 2 |
| 8 | P08-000950A | ROLLER | 1 |
| 9 | P02-031950A | ROLLER | 1 |
| 10 | P01-050810C | GUIDE SUPPORT | 1 |
| 11 | P01-050800B | GUIDE SUPPORT | 1 |
| 12 | P06-0041200 | POSITION CONE | 2 |

HOOD UNIT

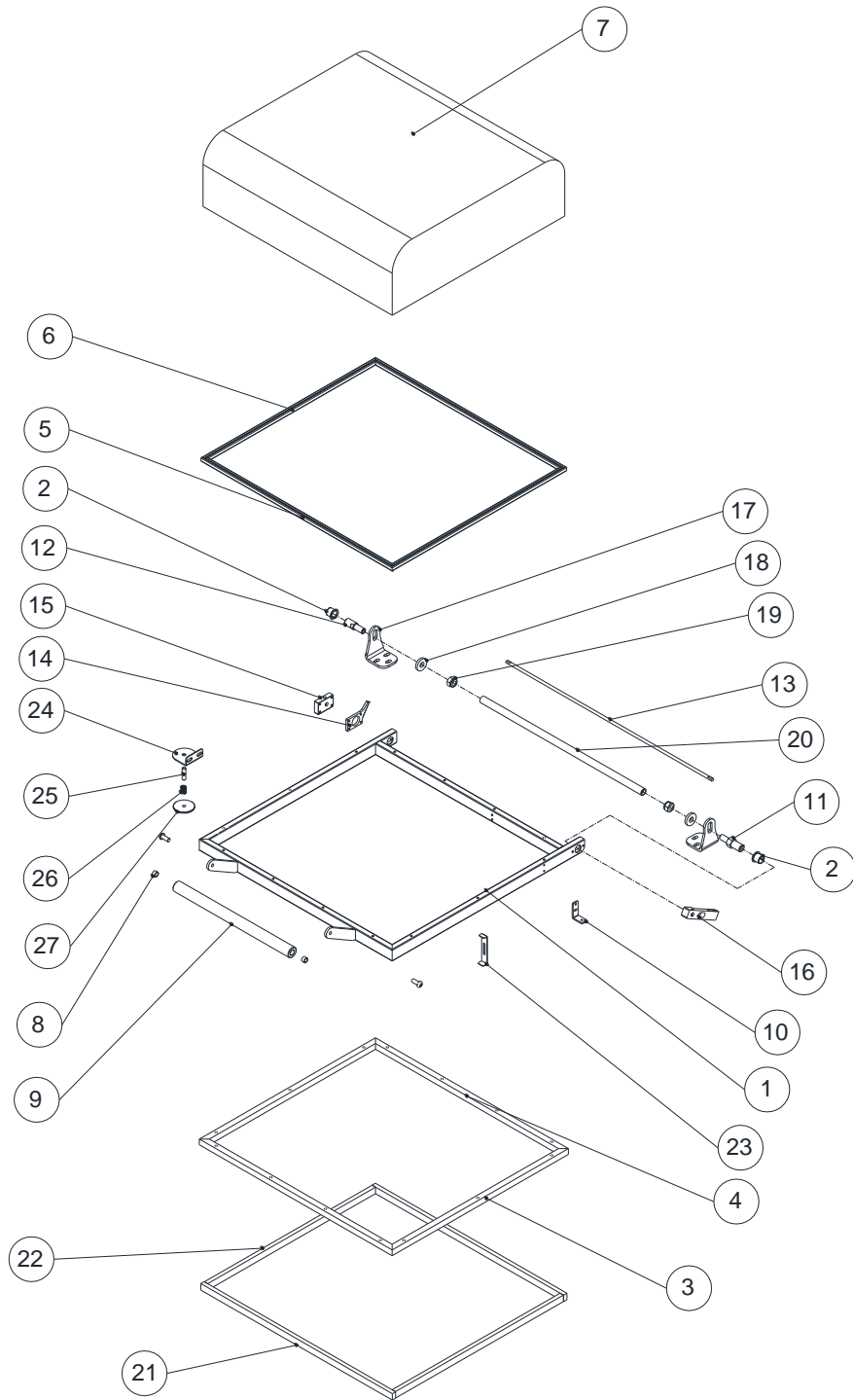

| HOOD UNIT | | | |
|-----------|---------------|-----------------------------|------|
| # | PART NUMBER | ITEM | Q'TY |
| 1 | | HOOD SEAT BRACKET | 1 |
| 2 | P1104-0316150 | BUSHING | 3 |
| 3 | P02-023720A | ALUMINUM SEAT - LEFT/RIGHT | 2 |
| 4 | P02-023710A | ALUMINUM SEAT - FRONT | 2 |
| 5 | | PLASTIC COVER FIXER - SHORT | 2 |
| 6 | | PLASTIC COVER FIXER - LONG | 2 |
| 7 | P06-0061000 | PLASTIC COVER | 1 |
| 8 | P02-0015400 | RING | 2 |
| 9 | P06-0059900 | HANDLE | 1 |
| 10 | P01-050350A | SWITCH LEVER | 1 |
| 11 | P02-031820A | HOOD PIVOT - LONG | 1 |
| 12 | P02-0318300 | HOOD PIVOT - SHORT | 1 |
| 13 | P1203-0002700 | TORSION SPRING BAR | 1 |
| 14 | P01-0503100 | STOPPER BRACKET | 1 |
| 15 | P02-0318400 | TORSION SPRING BAR FIXER | 1 |
| 16 | P02-0318500 | TORSION SPRING BAR ADJUSTER | 1 |
| 17 | | SEAT | 2 |
| 18 | | WASHER | 2 |
| 19 | P1102-0112BZ | SCREW M12 | 2 |
| 20 | P02-031970A | COVER SHAFT | 1 |
| 21 | P06-0038800 | RUBBER STICK - 1 | 2 |
| 22 | P06-0038900 | RUBBER STICK - 2 | 2 |
| 23 | P01-050430A | PUSHER | 1 |
| 24 | P01-0503400 | PAD FIXER | 1 |
| 25 | P02-0332100 | PAD SCREW (M8x30L) | 1 |
| 26 | P1201-0003900 | SPRING | 1 |
| 27 | P02-031890A | PAD | 1 |

STAND UNIT

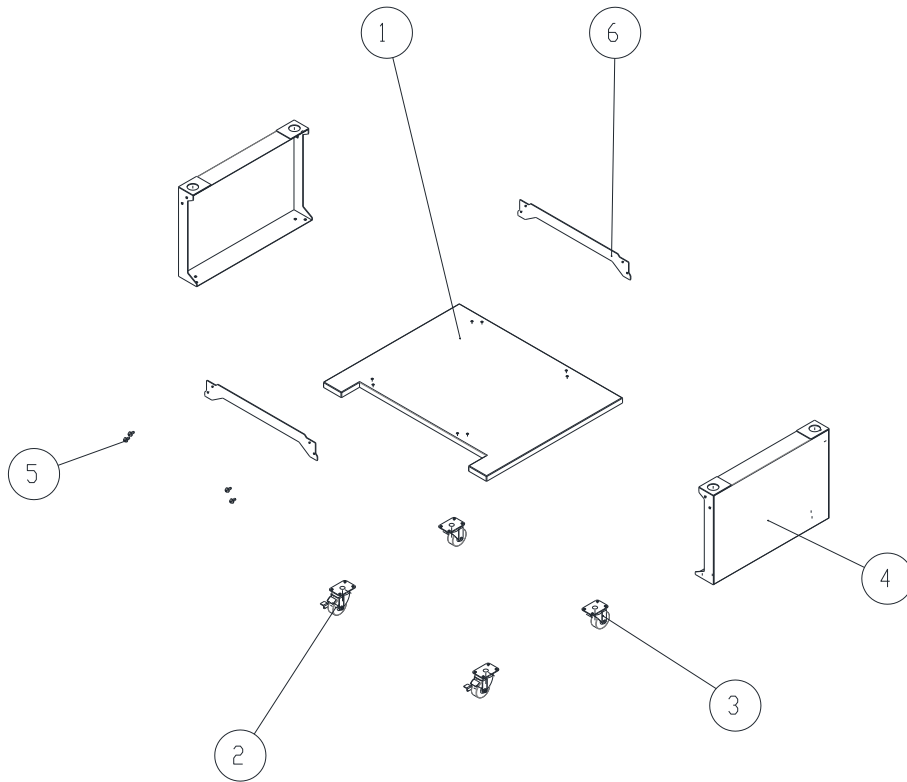

| STAND UNIT | | | |
|------------|---------------|-------------------|------|
| # | PART NUMBER | ITEM | Q'TY |
| 1 | | BASE | 1 |
| 2 | P1107-0000900 | CASTER WITH BRAKE | 2 |
| 3 | P1107-0000800 | CASTER | 2 |
| 4 | | SIDE FRAME | 2 |
| 5 | | SCREW M8*20 | 4 |
| 6 | | SUPPORT | 2 |

HEATING UNIT

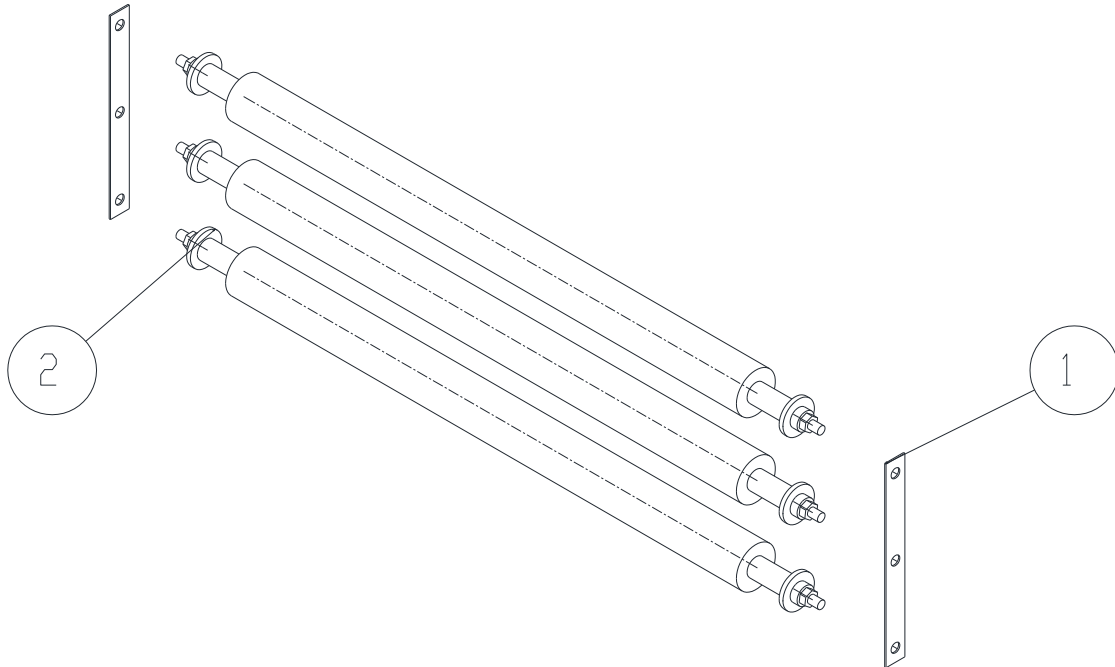

| HEATING UNIT | | | |
|--------------|-----------------|-----------------------|------|
| # | PART NUMBER | ITEM | Q'TY |
| 1 | P01-0272900 | HEATING ELEMENT FIXER | 2 |
| 2 | P0314-070000100 | HEATING ELEMENT | 3 |